



AIR CONDITIONING



REFRIGERATION



HEATING



# mini aqua®

## CONDENSATE REMOVAL PUMP

The world's slimmest condensate removal pump is designed to fit where other's can't!



12L/h max. flow



10m max. rec. head (flow rate 6L/h)



21dB(A)

### KEY FEATURES

- Ultra slim
- High performance
- Plug & play
- Anti siphon device

### SUITABILITY

- Up to 16kW / 54,000Btu/h
- High wall mini split systems; Ducted units; Floor standing & Chassis units
- ✓ **Perfect for...** installing directly inside the unit



0.18<sup>†</sup> kg

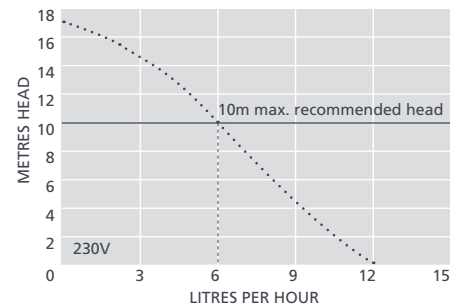
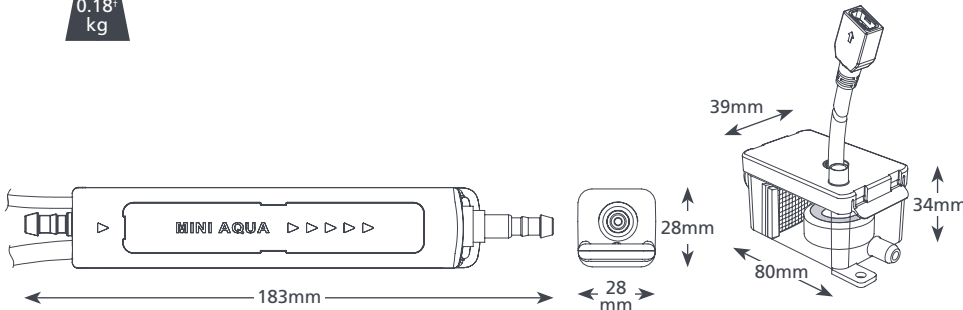

### MINI AQUA SPECIFICATIONS

Max. flow	12L/h @ 0 head
Max. rec. head	10m
Max. suction lift	2m
Sound level@1m	21dB(A)
Power supply	230V AC 50-60Hz 0.1A*
Rated Class	Non continuous II appliance <input type="checkbox"/>
Max. unit output	16kW / 54,000Btu/h
Max. water temp	40°C / 104°F
Discharge tube	6mm ID
IP Protection	IPX4
Safety switch	3.0A Normally closed
Thermal protection	✓
Fully potted	✓
Self priming	✓

### MINI AQUA OPTIONS

Mini Aqua	FP2406/2
-----------	----------

\* Other voltages available  
† Pump only

### SUGGESTED XTRA ACCESSORIES

Description	Part No.
1 Amp Fuse	FP2620
Tube To Soil Stack Adaptor	FP2038
Vinyl Tube Braided 1/4" (6mm)	AX5100
Inline Filter 16mm	FP2640

**Xtra** For more installation accessories take a look at our Aspen Xtra range

### IN THE BOX

Mini Aqua pump • 1.5m Plug & play power cable • Reservoir (inc. filter, float, lid) • 150mm Vinyl breather tube 6mm ID • Anti siphon device • 1.5m Suction breather tube 6mm ID • 220mm Blue inlet hose 14mm ID • Drain connector kit • Fixing kit • Install manual

- Download manual at [aspenspumps.com](http://aspenspumps.com)
- View install video at [aspenspumps.com](http://aspenspumps.com)

Information correct at time of going to press.

