



AIR CONDITIONING



REFRIGERATION



HEATING



# hi-lift 1L & 2L

## CONDENSATE REMOVAL PUMP

The world's only persaltic tank pump offers unsurpassed high head and unmatched reliability.

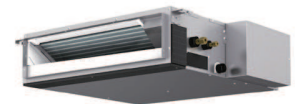

11L/h max. flow



12m max. head (flow rate 11L/h)

### KEY FEATURES

- High head
- Easy fit & maintenance
- Easy access clean tray
- Built in spirit level

### SUITABILITY

- Up to 14kW / 47,000Btu/h
- Ducted units; Floor standing & Chassis units; Cassette units; Refrigerated units / cold store

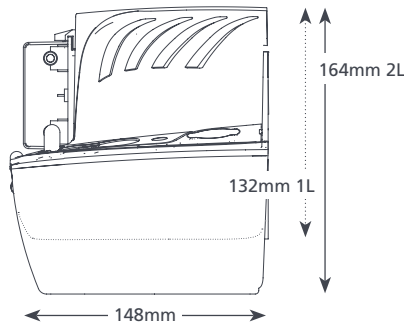
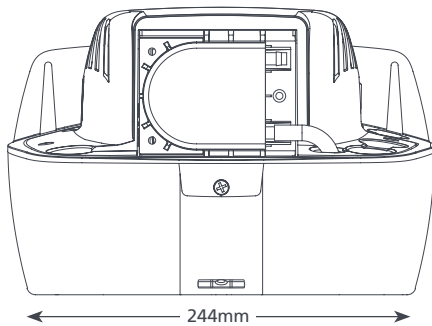

### HI-LIFT 1L & 2L SPECIFICATIONS

Max. flow	11L/h @ 0 head
Max. head	12m
Tank capacity	1L & 2L
Sound level@1m	51dB(A)
Power supply	230V AC 50-60Hz 0.4A*
Rated	Continuously
Class	I appliance
Max. unit output	14kW / 47,000Btu/h
Max. water temp	40°C / 104°F
Inlet/outlet	x3 25mm in, 6mm out
IP Protection	IPX0
Safety switch	3.0A Normally closed
Thermal protection	✓
Fully potted	n/a
Self priming	n/a

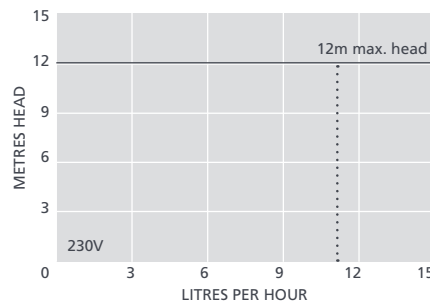

### SUGGESTED XTRA ACCESSORIES

Description	Part No.
Tank pump connector 16mm-21mm	FP2011
Tube To Soil Stack Adaptor	FP2038
Vinyl Tube Braided 1/4" (6mm)	AX5110

*Xtra* For more installation accessories take a look at our Aspen Xtra range

### HI-LIFT 1L & 2L OPTIONS

Hi-lift 1L	FP2099/2
Hi-lift 2L	FP2071/2

\*Other voltages available

### IN THE BOX

Hi-lift 1L or 2L pump • 2m Plug & play power cable • Fixing kit • Install manual

Download manual at [aspenspumps.com](http://aspenspumps.com)



[aspenspumps.com](http://aspenspumps.com)

+44 (0)1323 848842

[sales@aspenspumps.com](mailto:sales@aspenspumps.com)

Making life easier for the installer