



AIR CONDITIONING



REFRIGERATION



HEATING



# maxi lime

## CONDENSATE REMOVAL PUMP

Designed for larger units & humid environments. The Maxi Lime elbow pump gives you supreme power when needed. ('Pump only pack' also available).



35L/h max. flow



15m max. rec. head (flow rate 10L/h)



35dB(A)

### KEY FEATURES

- Sits in trunking elbow
- Left or right install
- Range of trunking systems
- Easy access for servicing

### SUITABILITY

- Up to 46kW / 157,000Btu/h
- Large commercial AC units; High wall split systems

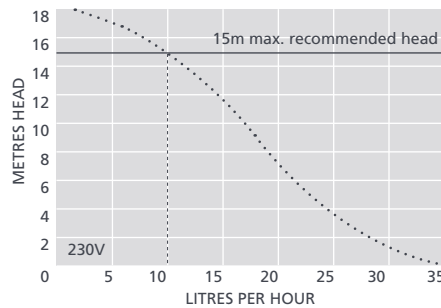
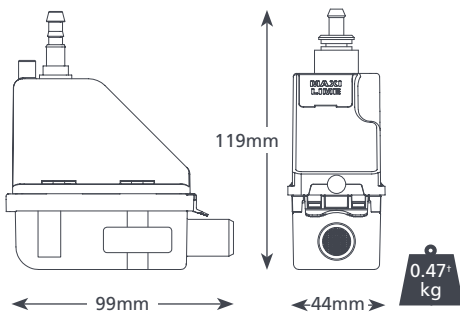

### SUGGESTED XTRA ACCESSORIES

System	Part No.
1 Amp Fuse	FP2620
Tube To Soil Stack Adaptor	FP2038
Vinyl Tube Braided 1/4" (6mm)	AX5100

*Xtra* For more installation accessories take a look at our Aspen Xtra range

### MAXI LIME SPECIFICATIONS

Max. flow	35L/h @ 0 head
Max. rec. head	15m
Max. suction lift	n/a
Sound level@1m	35dB(A)
Power supply	230V AC 50-60Hz 0.1A*
Rated	Non continuous
Class	II appliance <input type="checkbox"/>
Max. unit output	46kW / 157,000Btu/h
Max. water temp	40°C / 104°F
Discharge tube	6mm ID
IP Protection	IPX4
Safety switch	3.0A Normally closed
Thermal protection	✓
Fully potted	✓
Self priming	✓

### MAXI LIME SYSTEM OPTIONS

System	Colour	Part No.
BBJ (Aerco)	Ivory	FP2213
Inoac	Ivory	FP2214
Artiplastic	Ivory	FP2405
Maxi Lime Replacement†		FP2215

\* Other voltages available  
† Pump only – no trunking included

### IN THE BOX

Maxi Lime pump (inc. 750mm discharge tube with 6mm ID connector and 1.5m hard wired power cable) • 220mm Lime green inlet hose 14mm ID • 150mm Vinyl breather tube 6mm ID • Anti siphon device • Elbow front and back • 800mm conduit front and back • Internal conduit sleeve (Slimline system only) • Gasket (BBJ and Inoac/Inaba systems only) • Ceiling plate • Drain connector kit • Fixing kit • Install manual

- Download manual at [aspenpumps.com](http://aspenpumps.com)
- View install video at [aspenpumps.com](http://aspenpumps.com)



[aspenpumps.com](http://aspenpumps.com)

+44 (0)1323 848842

[sales@aspenpumps.com](mailto:sales@aspenpumps.com)

Making life easier for the installer