



AIR CONDITIONING



REFRIGERATION



HEATING



# standard

## CONDENSATE REMOVAL PUMP



Operated by an air conditioning cooling signal, the Standard peristaltic sets the standard for reliability. The remote install options means minimum future maintenance disruption.



6.5L/h max. flow



12m max. head (flow rate 6.5L/h)

### KEY FEATURES

- AC cooling signal operated
- Remote install possible
- Pumps contaminated water
- Can run dry

### SUITABILITY

- Up to 8.5kW / 29,000Btu/h
- High wall split systems; Ducted units; Floor standing & Chassis units

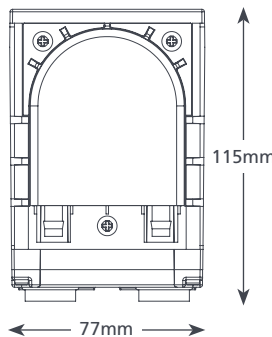
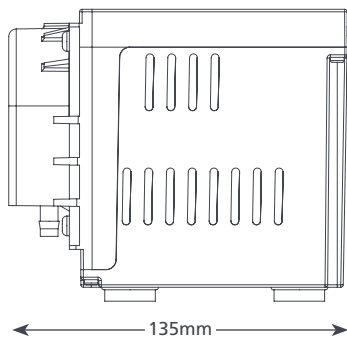

### STANDARD SPECIFICATIONS

Max. flow	6.5L/h @ 12m head
Max. head	12m
Max. suction lift	3m
Sound level@1m	47dB(A)
Power supply	230V AC 50-60Hz 0.2A
Rated	Continuously
Class	I appliance
Max. unit output	8.5kW / 29,000Btu/h
Max. water temp	40°C / 104°F
Inlet/outlet	6mm ID
IP Protection	IPX1
Safety switch	n/a
Thermal protection	✓
Fully potted	n/a
Self priming	✓

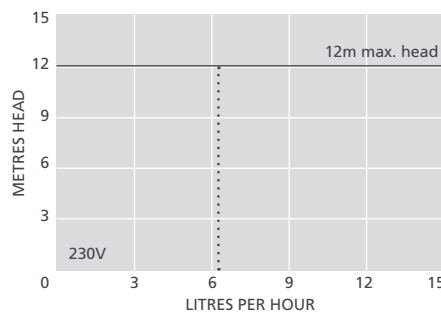

### SUGGESTED XTRA ACCESSORIES

Description	Part No.
Peri Spare Tube Kit	FP1282
1 Amp Fuse	FP2620
Tube To Soil Stack Adaptor	FP2038

*Xtra* For more installation accessories take a look at our Aspen Xtra range

### STANDARD OPTIONS

Standard	FP2081/2
----------	----------

### IN THE BOX

- Standard pump
- 2m Plug & play power cable
- Wall mounted bracket
- Fixing kit
- Install manual

Download manual at [aspenspumps.com](http://aspenspumps.com)

View install video at [aspenspumps.com](http://aspenspumps.com)



[aspenspumps.com](http://aspenspumps.com)

+44 (0)1323 848842

[sales@aspenspumps.com](mailto:sales@aspenspumps.com)

Making life easier for the installer